

MBPCX 25 T2 0,75kW Zone 2: FAN (Ex h IIB T4 Gc) + MOTOR (Ex db IIC T4 Gb) (502302517XD)

GENERAL DATA



PLASTIC ATEX FAN WITH FORWARD IMPELLER

MANUFACTURING FEATURES

- Housing made of PP-el plastic (for models size 35 and equal to or greater than size 45) other models PE-el casing
- Forward curved impeller in PP plastic.
- Motor support made of rolled steel sheet with polyester powder finishing coat.
- Stainless steel nuts and bolts.
- Standard asynchronous squirrel-cage motor, IP-55, class F insulation. Standard voltages 230/400V 50Hz for three phase motors up to 4kW and 400/690V 50Hz for higher powers. Equipped with ATEX motors

- Available positions (to be indicated in case of order): LG270, LG0, LG45, LG90, LG135, LG180, LG225, LG315, RD0, RD45, RD90, RD135, RD180, RD225, RD270, RD315.
- The indicated codes correspond to the model in position LG270

APPLICATIONS

Designed for inline installation, they are suitable for:

- Corrosive air transport.
- Chemical and petrochemical industry.
- Laboratories and gas cabinets.
- General ventilation in closed environments classified as ATEX zone 2.
- Maximum temperature of transported air: If it is clean air 70°C, other depends on the gas (see table in documentation)

UNDER REQUEST

- 60Hz fans and special voltages fans.
- Stainless steel motor support.

In compliance with the ATEX Directive 2014/34/UE. Certified ATEX IIIG with certified ATEX motor for areas 2 (gas)

PERFORMANCE CURVE

20 °C - m - 1.2 Kg/m³

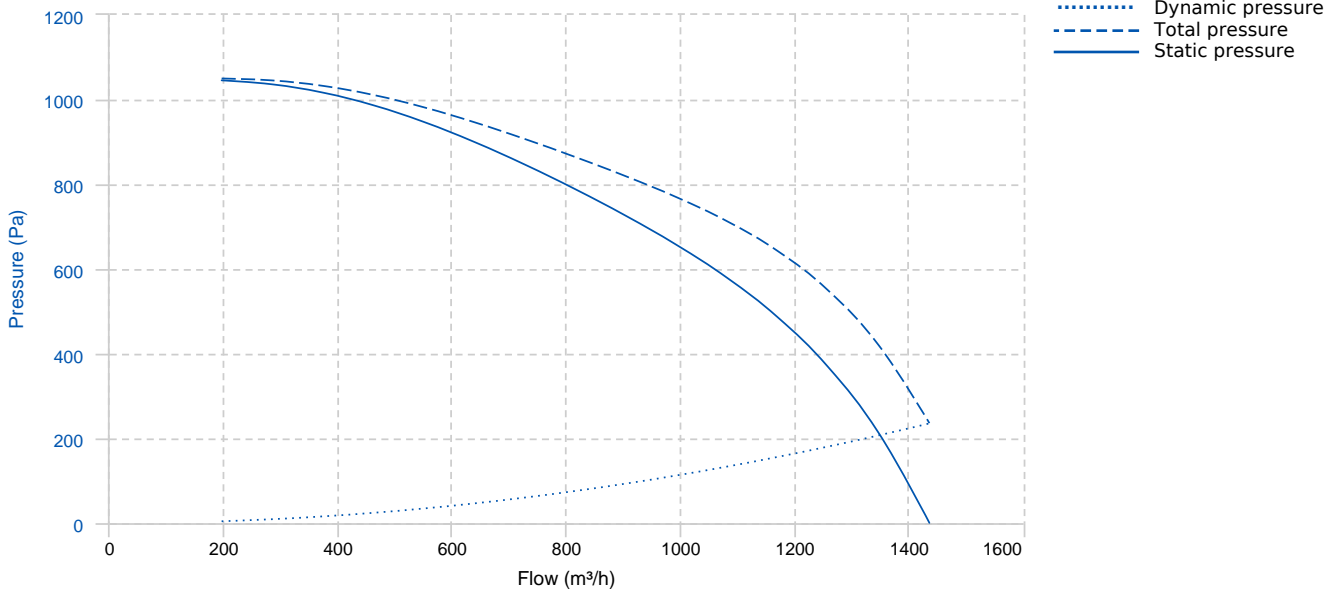

TECHNICAL DATA

Fan							
RPM	2870	Approx. weight	28 kg	Max. Flow	1435 m³/h		
Motor							
Power	0,75 kW	RPM	2870	I max. (400V)	2 A	Size	80
Approx. weight	9 kg	Efficiency (%)	73 %	FP	0.72		

DIMENSIONS

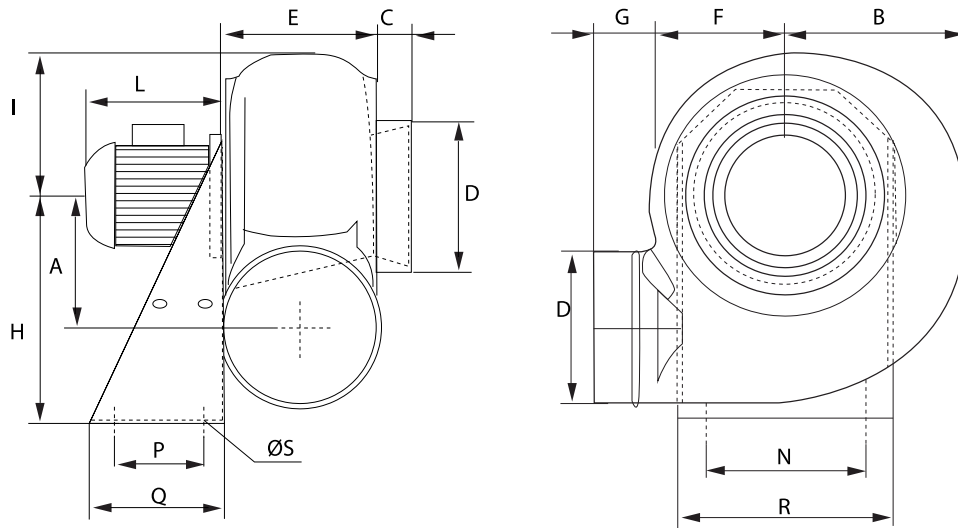

Dimensions (mm)									
A	183	B	228	C	40	DØ	160	E	153
F	188	G	60	H	310	I	210	L	220
N	255	P	100	Q	140	R	290	ØS	11

WIRING DIAGRAM

230V

400V

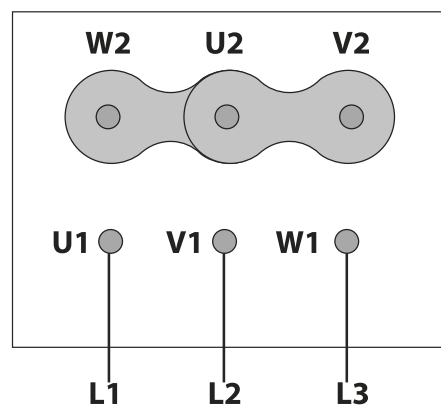
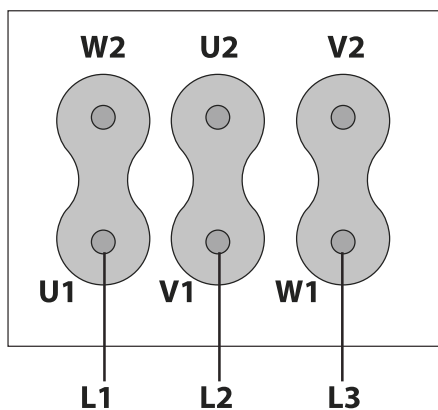

ACCESSORIES



ANTI-VIBRATING FLANGE 400°/2H
BA-400 15/16
REF: 960002067



ANTI-VIBRATION JOINT
JE 45
REF: A-300719201



ATEX SWITCH
INT 16 ATEX
REF: 510200016X



PVC FLEXIBLE JOINT
FJ Ø160
REF: FJ-160



DIFUSOR GRID
DG Ø160
REF: DG160



CIRCULAR GRAVITY DAMPER
CSC Ø160
REF: CSC160



ADJUSTABLE DAMPER
AD Ø160
REF: AD-160



DRAIN PLUG
PD 1
REF: PD1

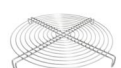

STAINLESS STEEL PROTECTION GRID
RPI Ø160
REF: RPI160



WALL SUPPORT
WS 1
REF: WS1



ANTI-VIBRATION BLOCK
AV 1
REF: AV-1



FREQUENCY SPEED CONTROLLER
SFC 230 I 4,2A *
REF: SFC230I004



FREQUENCY SPEED CONTROLLER
SFC 400 III 2,2A *
REF: SFC400III2



ANTI-VIBRATION RUBBER BLOCK
AVR (GENERIC)



ANTI-VIBRATION SPRING BLOCK
AVS (GENERIC)

SPARE PARTS

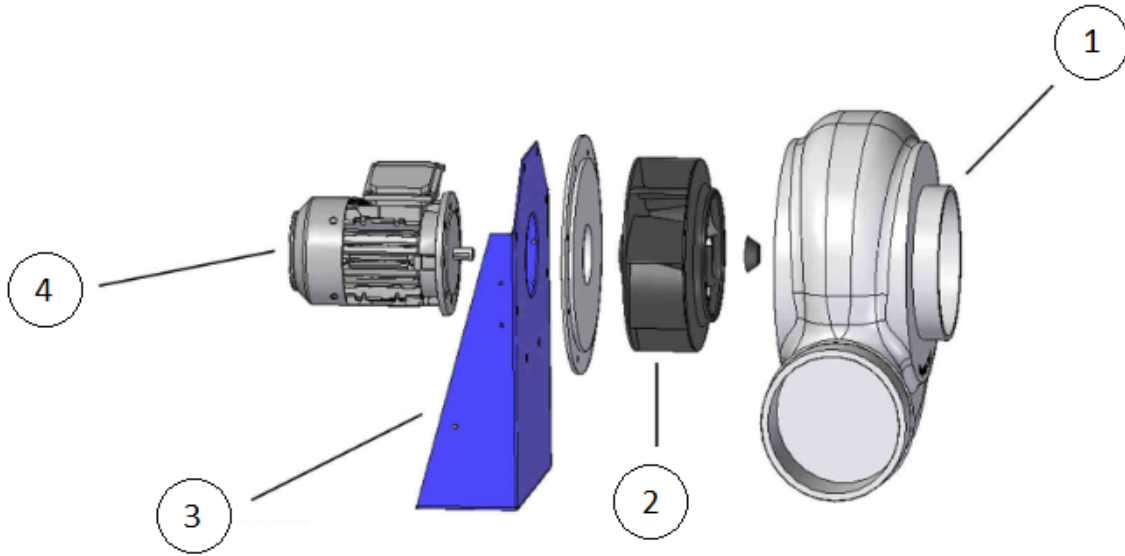

	Code	Model	Qty
1	T03102517	IMPELLER MBPCX 25 T2 0,75 kW LG	x1